



**DEPARTMENT OF FARM MACHINERY AND POWER ENGINEERING
COLLEGE OF AGRICULTURAL ENGINEERING AND TECHNOLOGY
CCS HARYANA AGRICULTURAL UNIVERSITY
HISAR-125004, HARYANA**



Phone:01662-255447

e-mail: fpm@hau.ernet.in

<http://hau.ernet.in>

hau.machinerytesting@gmail.com

SPECIFICATION SHEET OF ROTAVATOR

1.0	General:		
	a)	Name	:
	b)	Address of manufacturer	:
	c)	Address of applicant	:
	d)	Type	:
	e)	Make	:
	f)	Serial Number	:
	g)	Model	:
	h)	Year of manufacture	:
	i)	Recommended power of tractor, if tractor operated	:
2.0	Constructional Details		
2.1	Mainframe		
	a)	Material detail	:
	b)	Size	:
2.2	SIDE SUPPORT		
	a)	Type of frame	:
	b)	Thickness of plate, mm	:
	c)	Method of fixing to main frame	:
2.3	SHIELD (TOP COVER)		
	a)	Type	:
	b)	Size of shield, mm	:
	c)	Thickness of sheet, mm	:
	d)	Method of fixing to main frame	:
2.4	TRAILING BOARD		
2.5	ROTOR UNIT		
	ROTOR SHAFT		
	a)	Type	:
	b)	Length of shaft, mm • Ground wheel side • Opposite to ground wheel side • Dia. of shaft	:
	c)	Size of rotor pipe, mm	:
	d)	Method of mounting blades on shaft	:
	e)	No. of blades on shaft	:

	f)	Dia of rotor with blades, mm	:	
	g)	Tractor PTO rpm corresponding to 1700 rpm of engine (on load)	:	
	h)	Rotation of rotor shaft corresponding to 540 rpm of PTO shaft, rpm	:	
2.6	ROTOR BLADE			
	a)	Number	:	
	b)	Type	:	
	c)	Overall thickness, mm	:	
	d)	Thickness at tip, mm	:	
	e)	Method of mounting blades on rotor pipe	:	
	f)	Size of bolt, mm <ul style="list-style-type: none"> • Length • Diameter • Pitch 	:	
	g)	Size of spacer, mm <ul style="list-style-type: none"> • Length • Diameter (Inner/Outer) 	:	
	h)	Distance between two adjacent blades, mm	:	
	i)	Peripheral speed of rotor blades (m/sec)	:	
	j)	Speed index	:	
	k)	Blade bracket size, mm	:	
	l)	Method of arrangement of blade on rotor shaft	:	
	m)	Clearance of blade from the tip of the blade to ground, mm	:	
2.7	Depth control Mechanism			
	a)	Method of depth control adjustment	:	
	b)	Range of depth adjustment, mm	:	
2.8	Skid			
	a)	Type & Material	:	
	b)	Size, mm <p style="text-align: center;">Peripheral length Width Thickness of plate</p>	:	
	c)	No. of skids	:	
	d)	Method of fixing	:	
2.9	Adjusting Rack			
	a)	Type	:	
	b)	Size of flat, mm	:	
	c)	Range of depth adjustment, min-max (mm)	:	
	d)	Method of fixing	:	
	e)	Bolt size, mm	:	
2.8	POWER TRANSMISSION SYSTEM			
	Method of transmission			

Notation	As per IS: 4931- Oct. 2004 mm	mm
A	54.0 (min)	

B	76.0 (min)	
D ϕ	34.79 \pm 0.06	
d ϕ	28.91 \pm 0.05	
G	7.0	
H	38.0	
I	25.0 \pm 0.5	
J	ϕ 8.3	
R	6.7 \pm 0.25	
S	8.69	
α	30 °	

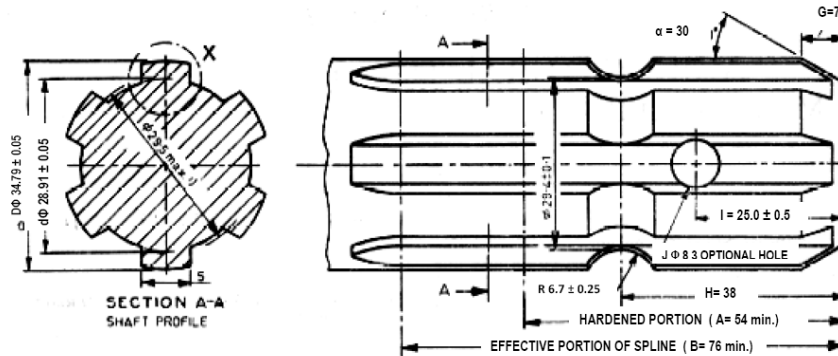

Power Take Off shaft

2.9	Gear box (Primary Reduction Unit)		
	a)	Type	:
	b)	For 540 PTO RPM	:
	c)	For 1000 PTO RPM (optional)	:
	d)	No. of teeth on pinion	:
	e)	No. of teeth on bevel gear	:
	f)	Overall Reduction ratio at gear box	:
	g)	Oil capacity, l	:
	h)	Oil change period, h (apa)	:
	i)	Recommended grade of oil, apa	:
	j)	Length of power transmission shaft (mm) (from gear box to secondary reduction unit)	:
	k)	Dia. of shaft (mm)	:
	l)	Provision of breather & Dipstick	:
	m)	No. of bearings	:
2.9.1	Gear box (Secondary Reduction Unit)		
	a)	Type	:
	b)	No. of teeth on driver gear	:
	c)	No. of teeth on Idler gear	:
	d)	No. of teeth on driven gear	:
	e)	Overall Reduction ratio	:
	f)	No. of bearings At drive shaft At idle shaft At driven shaft	:
	g)	RPM obtainable at rotavator shaft	:
	h)	Oil capacity (ltr)	:
	i)	Recommended grade of oil, apa	:

	j)	Oil change period, h (apa)	:	
	k)	Oil level checking and filling	:	

Name of Gear	No. of teeth	
	For 540 PTO RPM	For 1000 PTO RPM
N ₁ or N ₃	N ₁ = 17	N ₃ = 12
N ₂ or N ₄	N ₂ = 19	N ₄ = 23
N ₅ (Bevel Pinion)		
N ₆ (Bevel Gear)		
N ₇ (Driver Gear)		
N ₈ (Idler Gear)		
N ₉ (Driven Gear)		

Gear box assembly

2.10	Propeller shaft		
	Type	:	
	Length of propeller shaft, mm	:	
	Mass of shaft	:	
	Provision for locking	:	
	Provision for safety Clutch /device	:	

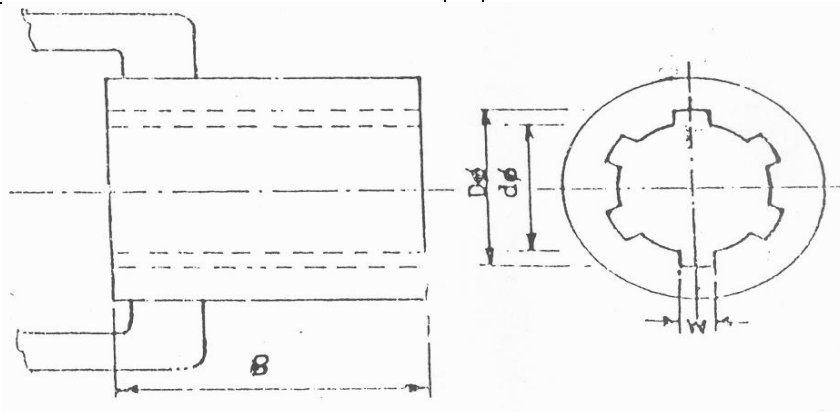

PROPELLER SHAFT

Notation	As per IS:4931-2004, mm	mm
Dφ	34.93 ± 0.03	
dφ	29.7 ± 0.1	
W	8.69	
B	54 (Min)	

2.11	Three point linkage		
	a)	Type	:
	b)	Specifications of Hitch pyramid	:
			As per IS:4468 Part-I, 2001 (Cl.5.1) & Part-II, 1998 (Cl.5.1) (All dimensions are in mm)

Sr.	Dimension	Description (Refer Fig.)	Dimension in mm
Upper Hitch attachments			
1	d ₁	Diameter of hitch pin hole	
2	b' ₁	Width between inner faces of yoke	
3	b' ₂	Width between outer faces of yoke	
Lower hitch points			
4	D ₂	Dia of hitch pin	
5	b' ₃	Linch pin hole distance	
6	l	Lower hitch point span	

Other dimensions		
	Diameter of lynch pin hole	
7	d	For upper hitch pin
8		For lower hitch pin
9	h	Mast height

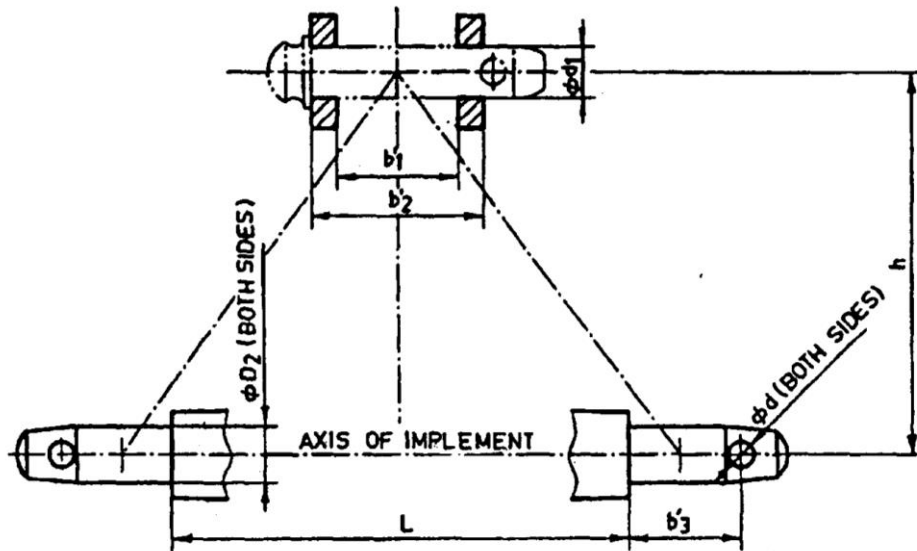

Fig. : Implement Hitch Attachment

2.12	Overall dimensions (mm) :	
a)	Length	:
b)	Width	:
c)	Height	:
d)	Ground clearance	:

Place:

Date:

Signature: _____

Name : _____

Designation: _____