



**DEPARTMENT OF FARM MACHINERY AND POWER ENGINEERING
COLLEGE OF AGRICULTURAL ENGINEERING AND TECHNOLOGY
CCS HARYANA AGRICULTURAL UNIVERSITY
HISAR-125004, HARYANA**



Phone:01662-255447

e-mail: fpm@hau.ernet.in
<http://hau.ernet.in>
hau.machinerytesting@gmail.com

SPECIFICATION SHEET OF TRACTOR OPERATED CHAFF CUTTER

1.0	General	
	Name of Machine	
	Name and address of Manufacturer	
	Name and address of applicant	
	Selling price in India	
2.0	Technical Specification	
	Make	
	Model	
	Type	
	Size	
	Serial No.	
	Year of Manufacture	
	Size of blade	
	Suitability	
3.0	Constructional Details	
3.1	Stand	
	Type	
	Size of angle iron	
	Size of supporting angle iron	
	Size of Platform	
	No. and size of holes for Fitting the chaff cutter assembly	
3.2	Power unit (Splined end of input shaft (Ref. Fig.1)):	

Dimension of Implement Power Input Shaft As per IS: 4931-2006

Sr.	Specification/ Notations (Refer Fig.1)	Dimensions
1	PTO Type 1/2/3	
2	Nominal speed (rpm)	
3	Nominal dia.(mm)	
4	Number and type of splines	
Dimensions (mm)		
5	D Φ	
6	d Φ	
7	B Φ	
8	A Φ	
9	W	
10	a	

11	b	
12	c	
13	x	
14	B	

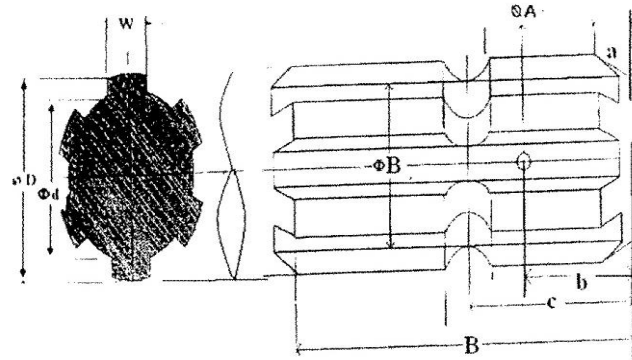

Fig. 1 Dimension of Implement Power Input Shaft

2.11	Propeller shaft:	
	a)	Type and material
	b)	Length of shaft (mm)
		Minimum
		Maximum
	c)	Mass of shaft (kg)
	d)	Provision for locking

Propeller Shaft Insert Dimensions As per IS: 4931-1995

Sr.	Notations (Refer Fig.2)	
1	$D \Phi$	
2	$d \Phi$	
3	W	
4	B	

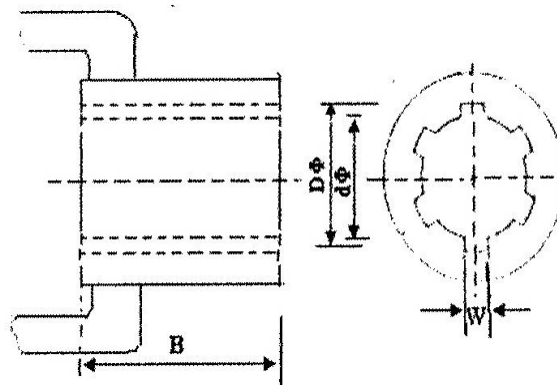

Fig. 2 : Propeller Shaft Insert Dimensions

3.3	Main Power Transmission	
	Type	
	Material and size of motor pulley	
	Size of flywheel pulley	
	Type and size of belt	
	Speed reduction from motor pulley to flywheel pulley	
	Arrangement for belt tensioning	

3.4	Fly Wheel	
	Constructional details	
	Diameter of flywheel	
	Thickness of flywheel	
	Size of 'S' shape casting for blade mounting	
	Size of central bush	
	No. size of holes on the 'S' shape casting for blade mounting	
	Mass of flywheel	
3.5	Chaffer Blades	
	Rotating Blades	
	Number of blades	
	Material of blades	
	Dimension of blade	
	Method of mounting	
	Fixed Blades	
	Number of blades	
	Size	
	Method of mounting	
	Recommended clearance between fixed and rotating blades	
	Method of clearance adjustment	
3.6	Feeding assembly	
	Main shaft	
	Material	
	Length of shaft	
	Diameter of Shaft	
	No. & type of bearings	
	Method of shaft mounting	
	Method of lubrication	
	Gear Box	
	Constructional details	
	Type	
	Material	
	No. of worms	
	No. of gears	
	Details of Worm	
	Type	
	Length	
	Thickness & depth of teeth	
	Number & size of holes for locking the worm on main shaft	
	Details of gear	
	Type	
	Number of teeth on each gear	
	Pitch	
	Number and size of holes provided for locking on shaft	
	Method of power transmission	

	Method of lubrication	
	Recommended lubricant	
3.7	Feed Rollers	
	Number of rollers	
	Type	
	Material	
	Lower Roller	
	Width & diameter of roller	
	Effective width of roller	
	No. of teeth on each roller and their configurations	
	Type of teeth and pitch	
	Size of teeth	
	Type of roller shaft	
	Size of roller shaft	
	No. & type of shaft bearing	
	Size of bush	
	Provision for lubrication	
	Upper Roller	
	Width & diameter of roller	
	Effective width of roller	
	No. of teeth on each roller and their configurations	
	Type of teeth & pitch	
	Size of teeth	
	Type of roller shaft	
	Size of roller shaft	
	No. and type of shaft bearing	
	Size of bush	
	Provision for lubrication	
	Space between the axis of upper & lower roller (Minimum & maximum)	
	Method of space adjustment	
	Speed of feeding rollers	
3.8	Feeding mechanism	
	Type of Feeding	
	Material	
	Height of feeding tray	
	Length of feeding tray	
	Size (width x depth) of feeding tray at outer end & inner end	
	Angle of inclination of tray	
	Method of mounting	
4.0	Safety Arrangements	
5.0	Transport Arrangements	
6.0	Overall dimensions	
	Length	
	Width	
	Height	

7.0	Mass of Machine	
	With prime mover	
	Without prime mover	
8.0	Color of Machine	

Place:

Date:

Signature: _____

Name : _____

Designation: _____